



# Servitherm

## Heaters

By **morganhope**   
INDUSTRIES LTD

### Hi-Tech Construction



The panel is constructed as a fibreboard sandwich, encasing the heat source consisting of a carbon fibre fabric element. This technology has resulted in a product which far outlasts conventional heaters using wire elements. The panel is finished with a specially extruded trim incorporating the fixing slot, details of which are explained on the next page. The heaters are fitted, as standard, with two safety thermal cut out devices as protection against overheating if accidentally covered. The heater comes complete with 2 metres of cable and a moulded 3 pin plug.

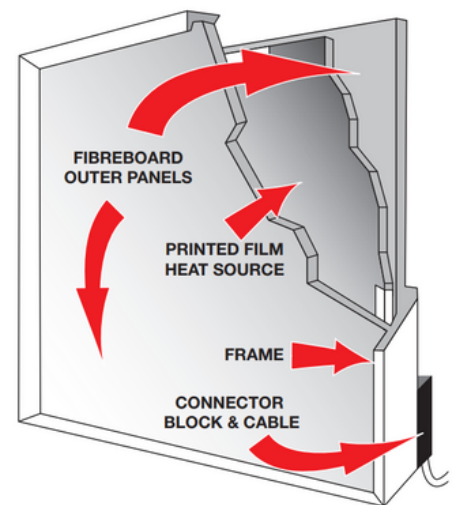

**Servitherm Panel Heaters are designed to provide heating at costs and locations never before available with conventional heaters.**

The unique features of the **Servitherm Panel Heaters** are its ultra slim construction and low running costs. Designed to provide a normal running surface temperature of between 60°C and 70°C, the panel can be fitted almost anywhere where heat is required. The panels are manufactured in a variety of sizes giving further versatility to a range of applications in commercial or domestic situations



...designed  
for economy  
and ecology

**Running costs  
from under 2.50p  
per hour**

- ISO 9002 Approved
- Low Wattage
- Extremely Economical
- Unobtrusive
- Easy To Fit
- Security Fittings
- No Control Dials
- Easy To Clean
- Smart Appearance
- Conforms To BS3456
- Patented GB 2244194

The **Servitherm Panel Heater** is delivered as a complete unit with no wiring required. The unit simply plugs into any 240 volt socket.

Installation to the required location is easy and the panel is supplied with all fittings - all that is required extra is a drill! To accommodate the many applications and site locations the Servitherm Panel Heater offers, the units are manufactured in a selection of sizes. Details of dimensions are contained under heading 'Your Questions Answered'.

The panels are white and finished with a quality frame. If required they can be decorated with a water based eggshell emulsion paint.

## 8 Standard Sizes

*All fixing screws and a locking spanner are supplied and fixture of the heating panels can be made to all conventional materials. The fixing screws are secured to the wall or other location and the frame surrounding the heater panel is then located onto the head of the fixing screw. The screw is then rotated to approximately a 45° angle with the locking spanner, to the secure panel.*

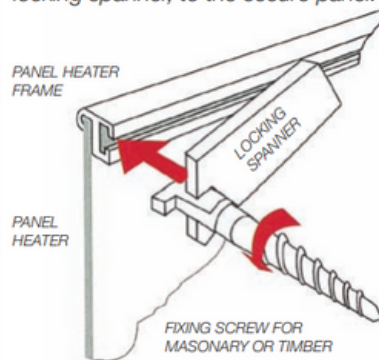

Supplied in White as standard with the following alternative heater colour options

-  Van Dyke
-  Bison
-  Bamboo

Due to the limitations in the printing process the above colours are representational and may vary with the final product. Clients should seek samples before proceeding with their order.

Receptions • Conservatories • Kennels • Catteries • Farms • Counters • Checkouts  
Airing Cupboards • Caravans • Church Pews • Offices • Anywhere in the Home No  
wiring - Simply plug into a socket

**Servitherm now offers a surface mounted electric heating system ideal for use in kennels, catteries, checkouts, counters, desks, airing cupboards, caravans and many other areas requiring localised comfort heating, with a running cost of as little as 3p per hour.**



Dog Kennels



Bathroom

British designed and manufactured, the Servitherm panel is an incredibly slim heating unit (one and a quarter inches - 30mm in thickness) and can be fitted virtually anywhere in an enclosed area. The radiant heat from the panel provides maintained comfort levels unlike other forms of heating, such as fan heaters, where the heat output becomes excessive.

The normal running surface temperature will depend on the environment to which the panel is installed but can average between 60°C and 70°C. Dual thermal auto-reset cutouts are fitted in the event of overheating caused by accidental covering of the panel.

Fitting the unit is easy and no special wiring is necessary- simply plug in to a socket or connect directly into a spur.

### *Technical Specification*

**The outer material used in the construction of the Electrical Radiant Panel Heater is resistant to impact damage and comprises of the following qualities.**



#### Effect of Water

Unaffected by water. Passes water-tightness to BS 4624 (1981) Test 15.

#### Moisture Movement

Ambient to saturated: 1mm per metre.

#### Effect of Frost

Unaffected by frost. No cracking or surface alteration when tested to BS 4642: 1981: Test 17

#### Biological

Resistant to attack by insects or vermin and will not nourish mould growth.

#### Chemical

Unaffected by dilute chemicals, brine, chlorine solutions and urine. pH value 8-10.

#### Compatibility

Non-caustic and will not promote corrosion; will not affect bitumous compounds but should be protected when in contact with unanodised aluminium

#### Fire

Class 0 to the building regulations. Class 1 surface spread of flame to BS 476: Part 7: 1991 of limited combustability to BS 476: Part 2: 1982. Will not give off toxic smoke or gases in the event of a fire.

**Note: All heaters incorporate thermal overload protection devices**

The mains lead supplied is 2 meters long and bonded to one corner of the heater. The cable used complies with British Standard and the Harmonised Code is HO5 VVF of 2 core amp.

# Your Questions Answered

## WHAT EXACTLY ARE THEY?

They are electric panel heaters that are designed to provide a constant level of radiated heat at low cost.

## HOW DO THEY WORK?

The panels are heated by a high technology carbon Impregnated fabric element and heat sealed within an electronically isolating film.

## WHAT SIZE ARE THEY?

The heaters are available in 8 different sizes, providing maximum flexibility.

## HOW MUCH DO THEY COST TO RUN?

The panel heaters are highly efficient, costing from as little as 2.94p per hour, with the largest unit costing less than 9p per hour at peak rate. The maximum loading is 360 watts.\*

## HOW ARE THEY FITTED?

The panels are supplied complete with the fittings and installation Instructions, all you need is a drill. To fix, simply cut the panel out of the packaging box and place squarely on the wall in the position you require. Drill through the guide holes marked on the outside of the box. Place the wall plugs and screws supplied into the drilled holes, tighten and then position the heads of the screws, at approximately 45° angle, into the back of the frame surrounding the heater. Use the spanner provided to lock the panel against the wall. The Installation instructions include a helpline telephone number: 01704 512000.

## WILL IT BE NECESSARY TO HAVE ANY SPECIAL ELECTRICAL WORK CARRIED OUT?

No, just plug in to an ordinary household socket.

## WHERE CAN THEY BE POSITIONED?

The heaters can be fixed horizontally or vertically and will fit almost anywhere.

## HOW MUCH CABLE IS SUPPLIED?

The heaters are supplied with 2 meters of cable.

## ON WHICH SIDE IS THE CABLE POSITIONED?

The cable is positioned to the right hand side of the heater facia as standard but can be fixed to the left to order.

## HOW LONG DOES THE PANEL TAKE TO HEAT UP?

The heaters reach their designated surface temperature within about 15-20 minutes.

## CAN THE TEMPERATURE BE CONTROLLED?

The heaters are designed to give a constant level of heat and there are no controls to worry about. If required, room thermostat switches can be used for extra control. Further advice regarding this subject can be obtained from an electrician or through our helpline.

## IN WHAT COLOURS ARE THEY AVAILABLE?

The heaters are supplied as standard in white with a matching frame. However, the heaters can be painted with any high quality (BS Standard) egg shell emulsion to create a new look.

## HOW DO I CLEAN THE HEATERS?

Simply sponge with soapy water.

## HOW HOT DO THEY GET?

The normal running surface temperature will depend on the environment to which the panel is installed but can average between 60°C and 70°C.

## IS IT POSSIBLE FOR CHILDREN OR ANIMALS TO BURN THEMSELVES ON THE HEATERS?

No, the surface temperature is not hot enough to burn.

## WHAT HAPPENS IF THE HEATER IS ACCIDENTALLY COVERED - WILL IT OVERHEAT?

No, two thermal cut-outs are contained within the heater. These ensure that if the heater is covered and the temperature rises, the panel will automatically switch off until the temperature reduces, restarting when ready.

## IS THERE A GUARANTEE PROVIDED?

Yes, the heaters are guaranteed for one year.

## CAN THE HEATERS BE USED ANYWHERE ELSE?

Yes, the heaters are ideal for most domestic situations, e.g. bedrooms, bathrooms, airing cupboards, lofts or kitchens and numerous commercial applications.

### \*Running costs per heater based on a tariff of 7.33p per unit

Model No.	Watts	Amps	Standard Sizes	Running Costs (less than)
DM2412	120	0.50	24x12ins 600x225mm	2.94p
DM2416	160	0.67	24x16ins 600x400mm	3.92p
DM2424	240	1	24x24ins 600x600mm	5.88p
DM2432	320	1.33	24x32ins 600x800mm	7.84p
DM2436	360	1.5	24x36ins 600x900mm	8.82p
DM3612	180	0.75	36x12ins 900x300mm	4.41p
DM4812	240	1	48x12ins 1200x300mm	5.88p
DM4816	320	1.33	48x16ins 1200x400mm	7.84p

Morgan Hope reserve the right to change specifications without prior notice.

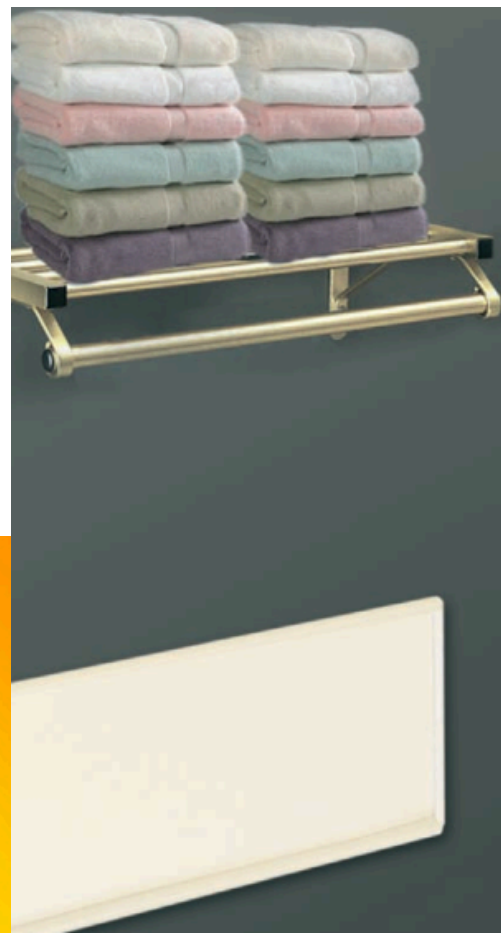

# Servithermcombi

## Radiant Slimline Heater Panel

Low wattage, Low Cost with proven heat efficiency

The Servitherm Combi heater has been tested to and complies with the European and British Standard BSEN 60335-2-30:1997

The Servitherm Combi is an energy efficient heater that provides a combination of radiated and convected background heat. A specially designed element, which covers the full surface area on the inside of the front panel, ensures maximum heat output, with low running costs.



Circulation of air through hidden vents, in the base of the radiator, ensure the optimum level of convected heat.

Emphasis has been placed on the **efficiency of the element**, which through design technology enables the panel to reach a temperature of up to 78°C, yet using a **maximum power consumption of only 260 watts**. Regulated by an internally mounted auto reset thermostat, the dual action of the radiant heat, plus convection through natural airflow, via the vents at the base and top front edge of the panel, ensures **optimum comfort** levels are achieved. The design features of the Servitherm Combi have resulted in a one-size heater, to meet most requirements, without the necessity of producing a varied product range

**Ideal for a wide range of uses such as conservatories, caravans, garages, or most applications in the home.**

- Low Wattage
- Neon On/Off Switch
- Extremely economical
- Easy to clean
- Unobtrusive
- Smart white appearance
- Easy to fit
- Slimline design
- Thermostatically controlled

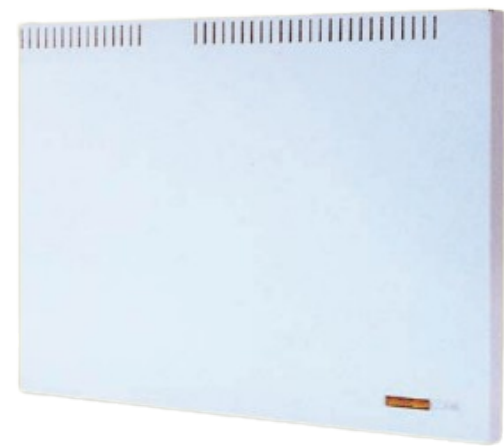

The panel is finished in white and measures 1000mm x 280mm (39.4" x 11.3") with a thickness of 25mm (1"). This size has been determined to cover most applications without occupying too much wall space and is ideally suited for fixing to conservatory dwarf walls. As the heat is directed through the front panel, the rear remains cool and is safe for wall mounting, without detriment to decoration. Also supplied with feet for freestanding

...leading

tomorrow's

technology

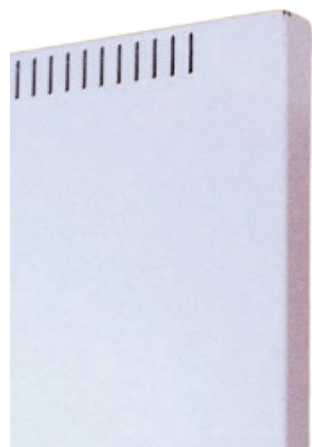

The slimline profile (only 25mm) of the Servitherm Combi allows for unobtrusive positioning.

\*Running costs per heater based on a tariff of 7.33p per unit

Model No.	Watts	Amps	Standard Sizes	Running Costs (less than)
Combi	260	1.15	1000x280mm	6.37p

Morgan Hope reserve the right to change specifications without prior notice.

# Servitherm Combi Heater Panels

## Usage & Installation Instructions

PLEASE READ CAREFULLY

The Servitherm Combi provides energy efficient background heat, resulting in low cost comfort levels. It is important to follow these instructions not only for safe installation and usage detail but also to ensure maximum advantage is taken of the heat output.

### CARE IN USAGE

Positioning of the heater panel will determine the best level of comfort. For localised heat it is suggested that the panel is positioned in an open area close by to where seating is to be arranged and not in distant corners of the room or behind furniture.

For background heat, locate in the best position to provide general circulation within the room area. Do not fix where furniture, curtains or other items are pushed against or cover the heater as, whilst the panel is protected by an auto re-set thermal cut-out, overheating may cause a danger and shorten the life of the heater. Failure of the thermal cut-out is protected by a one shot thermal fuse.

The panel is supplied with a 2 metre mains lead fitted with a 3 amp fused moulded 5 amp plug. Once switched on at the mains, the heater is controlled by a neon on/off switch at the side.

### RESTRICTIONS OF USE

The heater must only be used in dry conditions and cannot be fitted in areas such as bathrooms, or in the immediate vicinity of water usage areas such as sinks, showers or swimming pools and must not be used in Greenhouses or on Building sites. A specialist range of Servitherm Panels for use within the above areas is available. For more information ask for details on the "Servitherm Radiant Panel, reference DM Range".

### LOCATING AND FIXING THE HEATER PANEL

The Servitherm Combi heater can be freestanding by fixing the feet supplied in the packaging. Alternatively the panel can be wall mounted by fitting in accordance with the following instructions:

1. Prior to drilling ensure there are no electric cables, water or gas pipes buried in the wall area to be drilled. The wall should be solid or where fixing to a framework such as timber supports on conservatories, then the frame must be of sufficient construction to take the fixing screws. When fixing to hollow wall construction, seek professional advice from a contractor. Always position at least 50mm from the floor covering to allow for air flow. Do not carry out installation whilst heater is switched on. Isolate from the mains.
2. Refer to figure 1 for fixing details. Two types of back panels are produced, therefore figure 1a, which is the general panel type, shows two fixing holes and figure 1b shows four fixing holes. Only one pair of holes needs to be utilised depending on the required fixing centres.
3. Mark the drill points based on the measurements in the options shown in figures 1a and 1b, dependent on the back panel type. Ensure the panel is level and at the correct fixing height.
4. Drill the two fixing holes to a depth of approximately 40mm (1 1/2") and insert the wall plugs supplied. These are size No 6 and it is recommended that the drill bit used should be 5mm, to ensure a tight fit of the wall plugs. Slight increase of the hole size may be necessary if the wall plug is too tight.
5. Fix the white spacers on the screws (both supplied) and screw into the wall plugs or wood, leaving a small space of approximately 3mm between the screw head and the spacer, between which the heater panel will be located. (See figure 2).
6. At the base of the rear panel is a fixing tab which, when pulled down, is used to fix the bottom of the panel to the wall. Hang the panel on the screws as noted in item 5 and mark the hole position of the fixing tab. Remove the panel from the wall, drill a hole and plug, as sizes noted in item 4. Re-hang heater and screw tab to the wall.
7. Once the heater is securely fixed to the wall, it is safe to plug in and switch on.
8. Fixing the feet for freestanding. Remove the two screws and star washers at the base of the heater, position the feet over the fixing holes and refit the screws and star washers tightly.
9. The plug is the primary disconnection device and must be accessible at all times.
10. The heater must not be placed immediately below a socket outlet.

Your heater is supplied with a moulded plug and the wires are colour coded, as follows:  
EARTH - Green and Yellow,  
LIVE - Brown, NEUTRAL - Blue.  
Conforms to BSEN 60335-2-30:1997

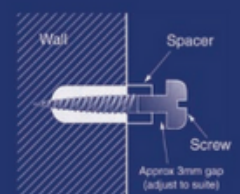
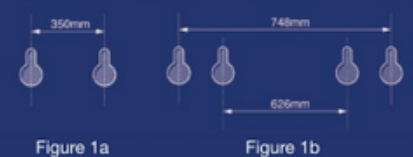

Figure 2

**NOTE:** This appliance **MUST** be earthed. Whilst not recommended, should it be necessary to fit a new heater plug, then if in doubt seek the advice of a qualified electrician. However, the supply cord cannot be replaced and if the cord is damaged, the appliance must be scrapped.

# Servitherm

## Heaters

**Morgan Hope Industries Limited**

Unit 1 Carpa House, Crowland Street, Southport, Merseyside PR9  
7RU. England

**Telephone:** +44 (0)1704 512000 **Fax:** +44 (0)1704 542632

**E-Mail:** [info@morganhope.com](mailto:info@morganhope.com)

**Website:** [www.morganhope.com](http://www.morganhope.com)